

DJ-LX 系列离心泵

DJ-LX Series centrifugal pump

高效率、低噪音、维护简单、经济、高洁净的解决方案

Solution for high efficiency, low noise, simple and economical maintenance, high purity



LX-10-40

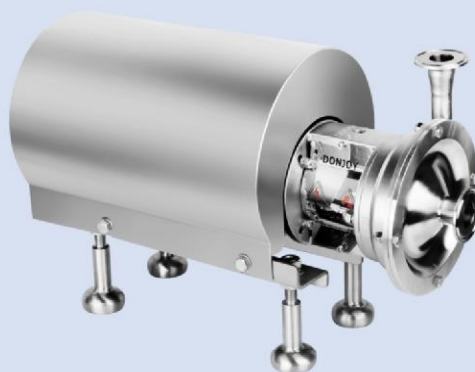

LX-05

随着市场需求的变化和技术的发展，我们希望在高洁净泵领域中树立新的技术标准，为此我们借助了流体力学分析软件和20多年积累的制造及工程应用的经验，进行一系列的技术升级和优化。

DONJOY DJ-LX 系列离心泵不仅优化了内部结构、叶轮设计、死角处理、机封压力平衡设计且机封完全被处在冲洗区域。我们还对泵外部卫生也进行了优化，使其内部更加卫生、外部减少死角，由于没有死角区域，它非常容易被CIP清洗、SIP杀菌等。另外我们对DJ-LX 系列泵保持了最大的灵活性组合应用，如，泵出口角度可以从 0° -135° 之间任意调整，泵盖采用手轮螺母，这样对泵维护和保养及机封的更换，保持了高效，降低了人员高度专业性的要求，而这些无需特殊的工具。因而达到了高效、卫生、高可靠性及低成本的目的，使DJ-LX 系列离心泵成为一款高性能的泵。

With the change of market demand and the development of technology, we hope to set up new technical standards in the field of high clean pump, for this reason, we have made a series of technology upgrades and optimization with the help of the fluid science software analysis and our more than 20 years experience in manufacturing and engineering application.

Donjoy DJ-LX series centrifugal pump, not only optimize the internal structure, such as impeller design, dead angle treatment, mechanical seal pressure balance design and the machine seal is completely in the flushing area, but also optimize external sanitation of the pump, which makes its internal absolute sanitation and external reduction of dead angle. Since there is no dead angle area, it is easy to be cleaned by CIP and sterilized by SIP. In addition, DJ - LX series pump, has kept the maximum flexibility of combined applications, for example, the pump outlet angle can be arbitrarily adjusted from 0° to 135°, the pump cover adopts hand wheel nut, which keeps high efficiency in the maintenance of the pump and replacement of machine seal, and reduces the highly professional requirements to maintenance personnel without special tools. Therefore, the DJ-LX series centrifugal pump has achieved the goal of high efficiency, health, high reliability and low cost, making it a high performance pump.

技术参数 Technical Specifications

流量 Flow rate	1m ³ /h-140m ³ /h
最高扬程 Max head	70M
温度 Temperature	-20℃到140℃
功率 Power	0.37KW-30KW
材质 Material	304 /316L, 1.4301/1.4404, ASME BPE 316L, 1.4435 BN2 Fe≤0.5%
表面处理 Surface treatment	≤ Ra0.8 μ m, ≤ Ra0.6 μ m, ≤ Ra0.4 μ m
机封 Mechanical seal	单机封、双机封 Single mechanical seal, double mechanical seal. 详见配置单 See Configuration Table
进/出口连接 Inlet/Outlet Connection	螺纹、卡箍、法兰、无菌法兰 Thread, Clamp, Flange, Aseptic flange
认证 Certification	3-A-02-10(N.O.1579); MD/06/42-EC(N.O.70521616101-00); FDA 177.2600; USP CLASS-II; EG/VO1935/2004

DJ-LX 系列离心泵

DJ-LX Series centrifugal pump

非常简单的维护、无需专用工具、专业人员
Very simple maintenance, no special tools required,
no professionals required

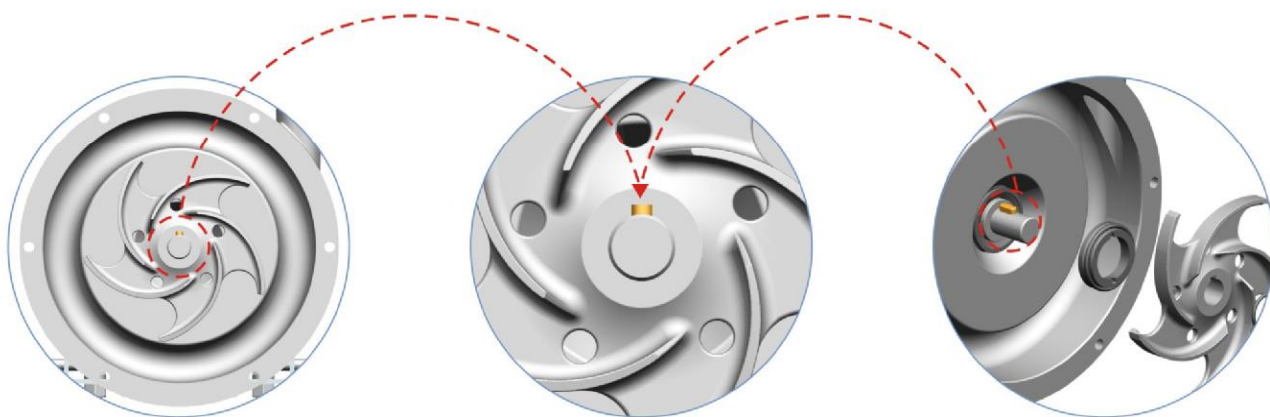
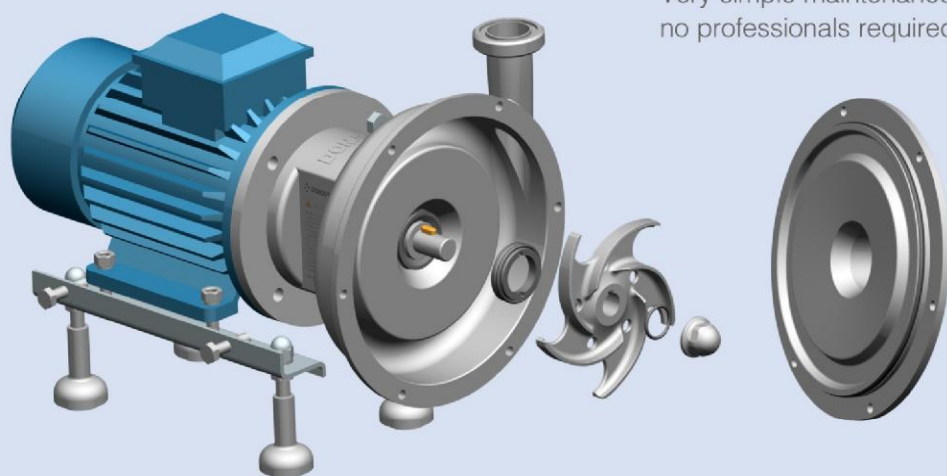

技术优势

- 维护拆卸和安装时，无需专业人员和专用工具，即可完成。
- 初始使用安装调试时，即使出现短暂反向旋转也不会损坏。
- 叶轮和轴之间是通过键槽连接固定，叶轮和机封动环之间是通过销钉固定，机封静环和泵体之间是通过异形法兰固定。
- 兼容单机封和双机封，只需要更换机封即可实现。

Technical Advantages

- Maintenance disassembly and installation can be completed without professional staff and special tools.
- Initial use of installation debugging, even if a short reverse rotation will not be damaged.
- Impeller and shaft are connected by keyway; impeller and mechanical seal rotating ring are connected by pin; mechanical seal static ring and pump body are connected by special-shaped flange.
- Compatible with single and double machine seal, only need to change machine seal.

DJ-LX 系列离心泵各种配置

DJ-LX series centrifugal pump various configurations



手轮螺母
Hand wheel nut



最低弯头排放接口
Bottom elbow discharge outlet



最低直管排放接口
Bottom straight discharge outlet

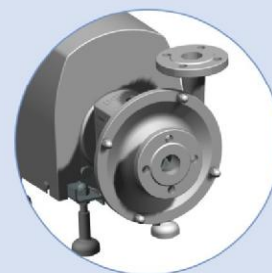

法兰连接进/出口
Flange inlet / outlet



无菌法兰(DIN 11864)进/出口
Aseptic Flange (DIN 11864)
Inlet/Outlet

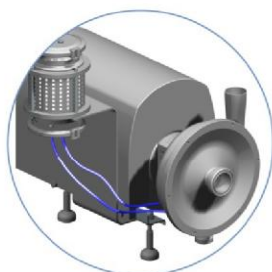

带冷却循环罐-LX系列离心泵
With cooling circulation tank-LX series centrifugal pump

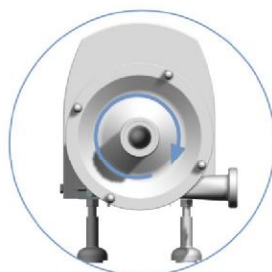

90° ...0° 倾斜出口
90° ...0° inclined outlet

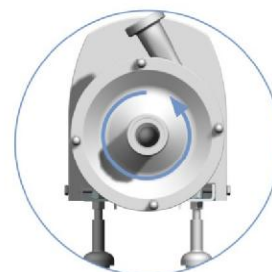

90° ...135° 倾斜出口
90° ...135° inclined outlet

泵进口/出口连接标准

连接方式：螺纹、卡箍、法兰、无菌法兰、KF、等。
标准：DIN SMS ISO IDF RJT ASME BPE 3A I-line

Pump Inlet/outlet Connection Standard

Connection: Thread, Clamp, Flange, Aseptic flange, KF etc.
Standard: DIN SMS ISO IDF RJT ASME BPE 3A I-line

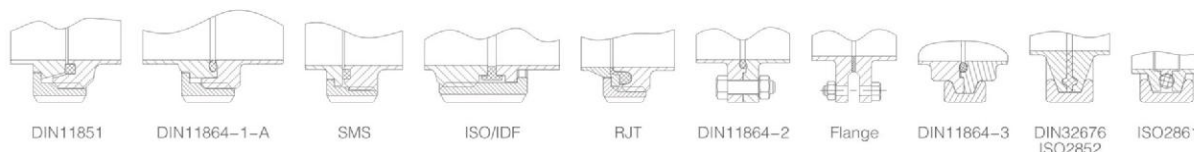

DJ-LX 系列离心泵机封设计

DJ-LX series centrifugal pump mechanical seal design

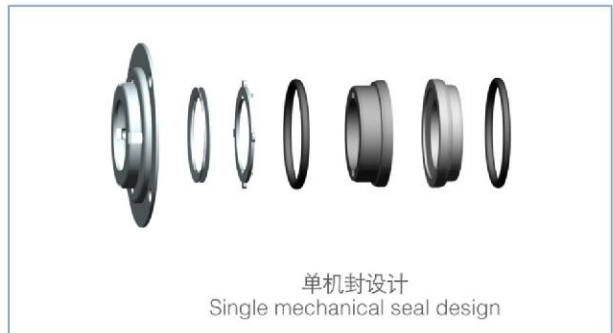
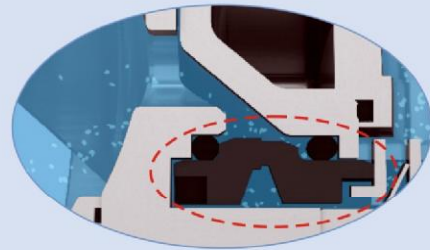
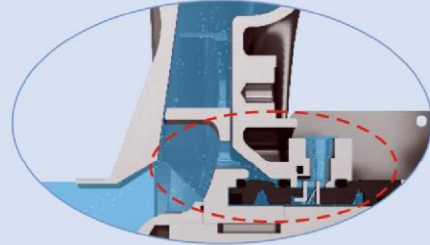
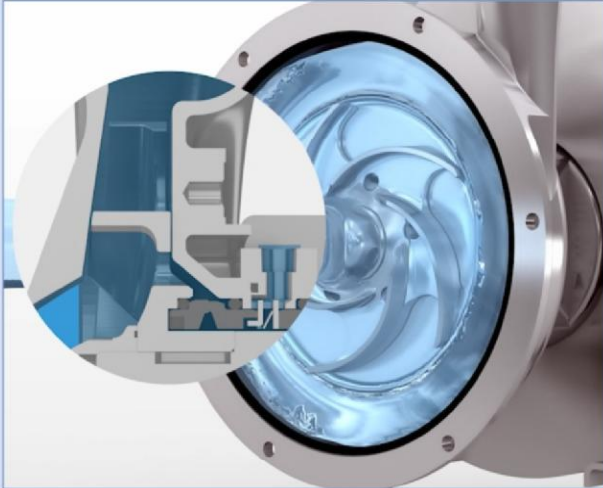

机封系统

DONJOY DJ-LX 系列离心泵机封，联合欧洲瑞典著名公司合作研发，机封设计具有压力平衡设计、超长使用寿命、极易拆装维护、无需特殊专用工具，卫生洁净符合和认证：欧盟EHEDG, 美国 3-A-02-11, FDA1772600等高洁净要求。并有丰富的机封配置方案。

Mechanical Seal Features

Donjoy DJ-LX series centrifugal pump mechanical seal is researched and developed together with European Swedish famous company. The mechanical seal is designed with pressure balance and super long working life, can be disassembled and maintained easily without special tools. The sanitary purity is according to EU EHEDG, USA 3-A-02-11, FDA1772600 and so on, and has lots of configuration.

机封配置 Mechanical Seal Configuration

1)SIC/C/EPDM	标准配置Standard
2)SIC/C/FKM	选型配置Optional
3)SIC/C/HNBR	
4)SIC/SIC/EPDM	
5)SIC/SIC/FKM	
6)SIC/SIC/HNBR	
7)TC/TC/EPDM	
8)TC/TC/FKM	
9)TC/TC/HNBR	

注意：以上配置适用于单机封和双机封。
Note: Above configurations is suitable for single and double mechanical seal

DJ-LX-05 迷你型离心泵

DJ-LX-05 Mini centrifugal pump

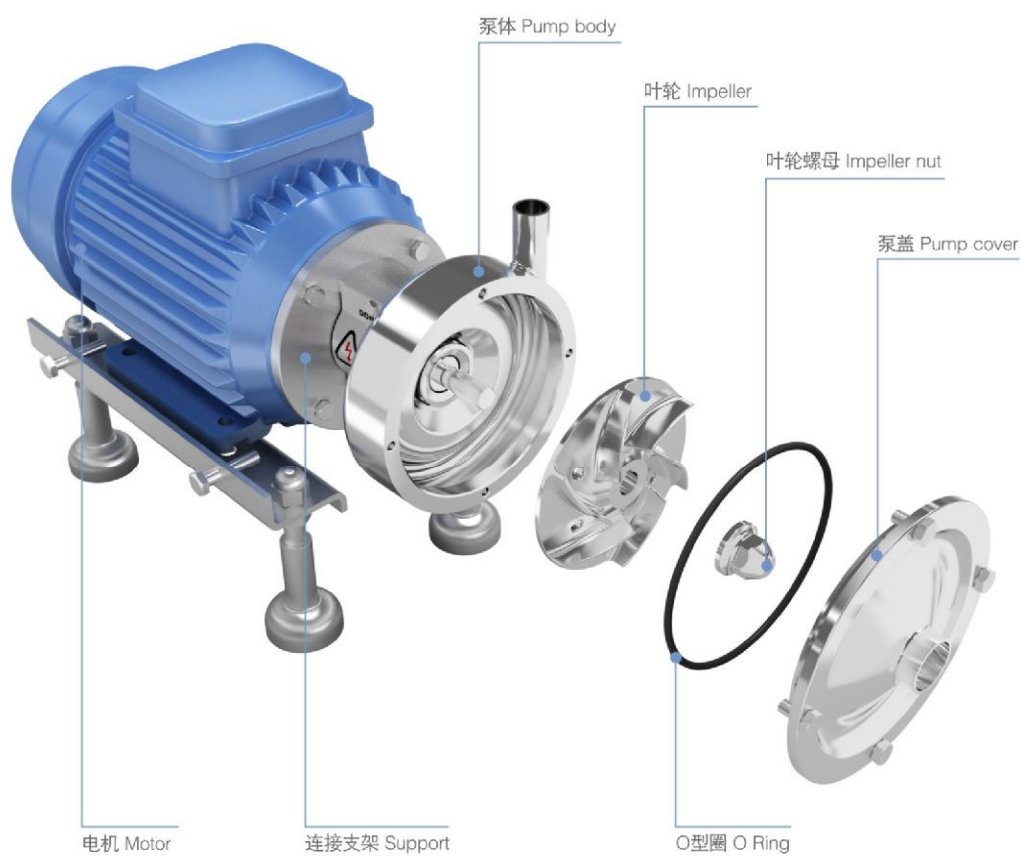
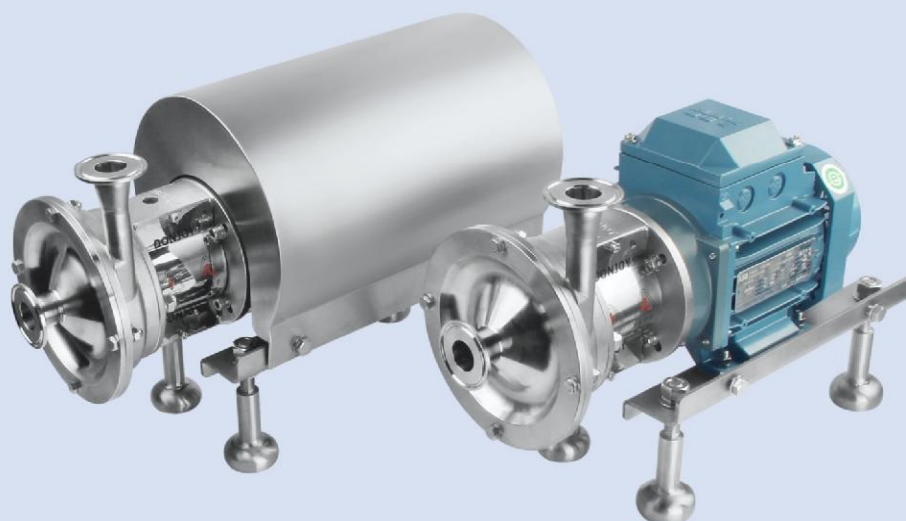

DJ-LX-10-40 离心泵

DJ-LX-10-40 Series centrifugal pump

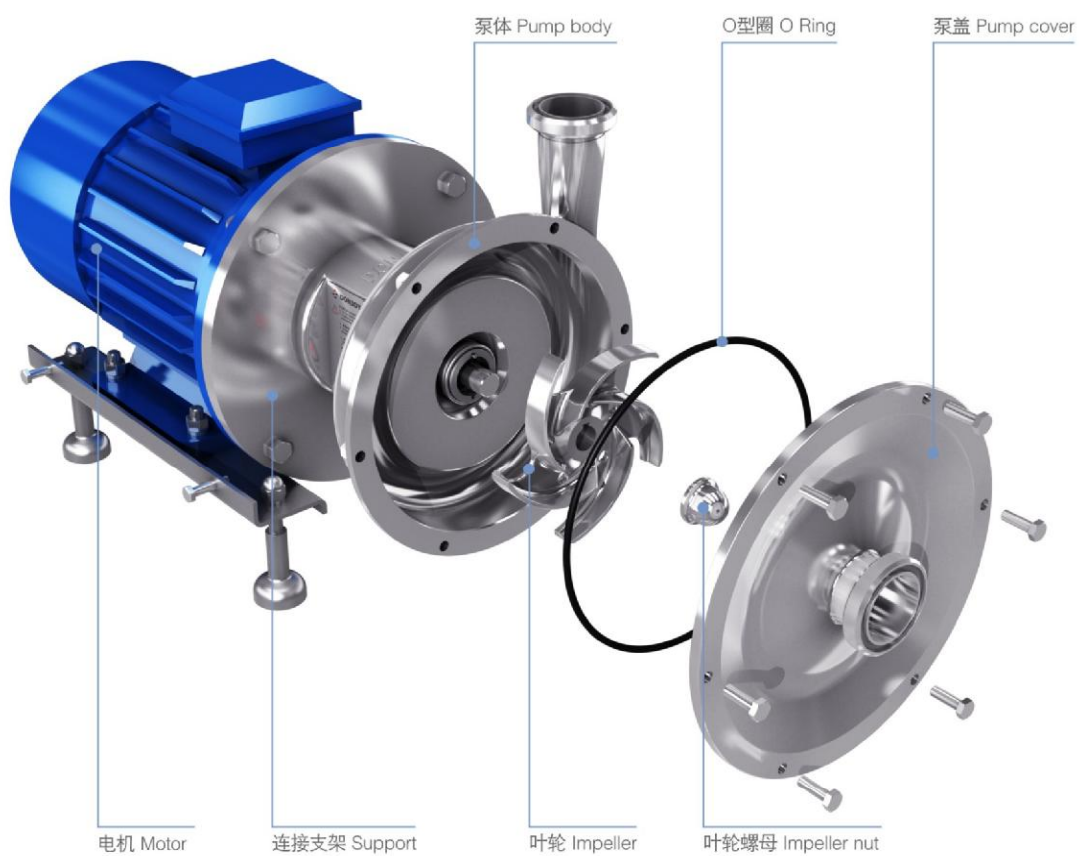
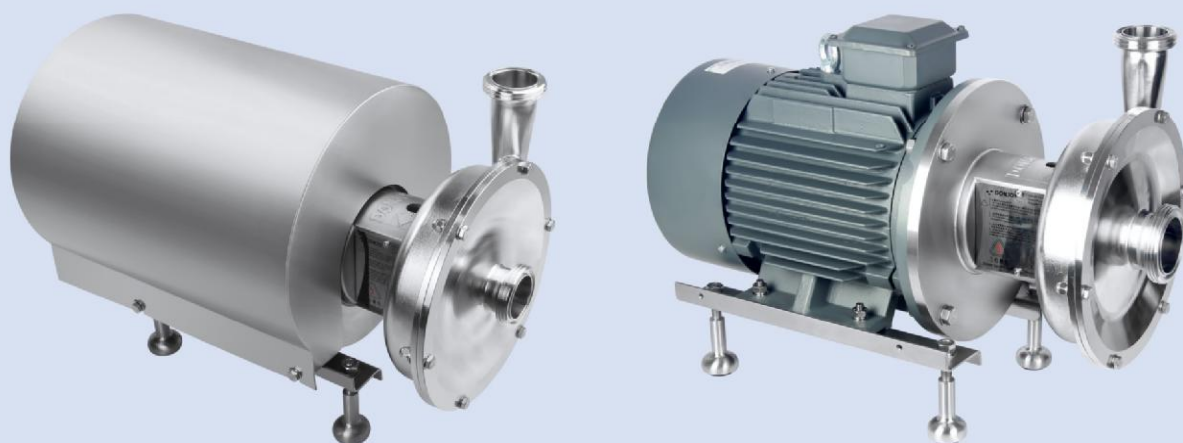

DJ-LX 离心泵型号说明

DJ-LX Centrifugal pump model instruction

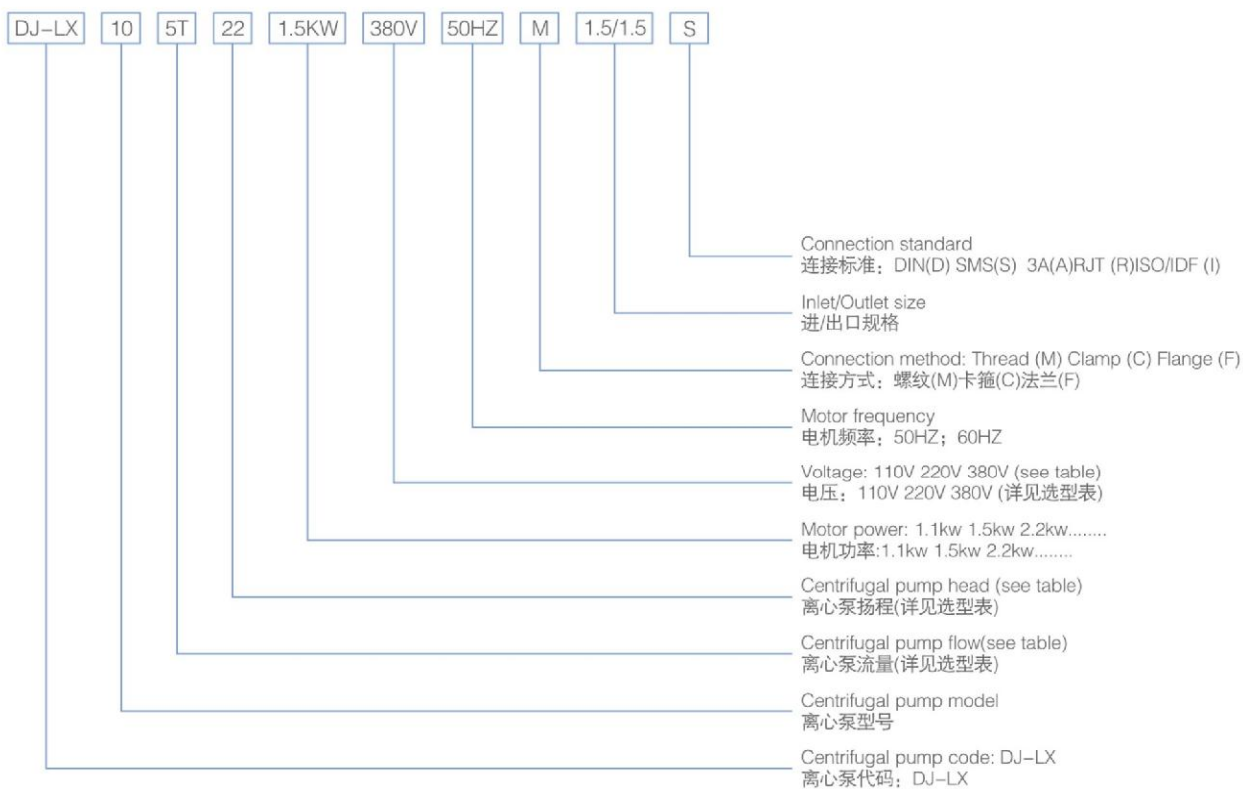

For example:
 举例: DJ-LX-10-5T-22-1.5KW-380V-50HZ-M-1.5/1.5-S

DJ-LX 离心泵选型表

DJ-LX Centrifugal pump selection table



型号 Model	功率 Power	流量(m³/h) Flow	扬程(M) Head	进口/出口 Inlet/Outlet	理论重量 KG
DJ-LX-05	0.55KW	2	20	1"0.75"	19
	0.75KW	3	16		22
	1.1KW	4	16		23
	1.5KW	5	14		29
	1.1KW	3	22		30
DJ-LX-10	1.1KW	5	22	1.5"1.5"	30
	1.5KW	3	22		36
	1.5KW	5	22		36
	1.5KW	8	22		36
	1.5KW	9	22		36
	1.5KW	12	20		36
	1.5KW	15	18		36
	2.2KW	18	16		40
	1.5KW	3	28		39
	1.5KW	5	28		39
DJ-LX-15	1.5KW	8	26	2"1.5"	39
	2.2KW	10	25		42
	2.2KW	15	22		42
	2.2KW	18	18		42
	3.0KW	18	18		54
	2.2KW	20	16		42
	3.0KW	20	16		54

型号 Model	功率 Power	流量(m³/h) Flow	扬程(M) Head	进口/出口 Inlet/Outlet	理论重量 KG
DJ-LX-20-1	2.2KW	5	36	2"1/2"	47
	3.0KW	5	36		56
	3.0KW	10	36		56
	4.0KW	10	36		61
	4.0KW	15	35		61
DJ-LX-20-2	4.0KW	20	33	2.5"1/2"	61
	4.0KW	25	30		61
	5.5KW	25	30		83
	5.5KW	30	30		83
	5.5KW	38	22		83
DJ-LX-25	5.5KW	20	40	2.5"1.5"	82
	5.5KW	25	37		82
	5.5KW	30	36		82
	7.5KW	40	30		86
	7.5KW	45	28		86
DJ-LX-30	4.0KW	5	50	2.5"1.5"	61
	5.5KW	10	50		82
	5.5KW	15	48		82
	5.5KW	20	45		82
	5.5KW	10	60		83
DJ-LX-30	5.5KW	15	55	2.5"1.5"	83
	5.5KW	20	50		83
	7.5KW	20	50		87
	7.5KW	25	45		87
	7.5KW	30	40		87

注意：以上数据图相关尺寸不作为实物最终依据，东正保留对于数据更新权限不再另行通知。
 Note: The relevant dimensions of the above data diagrams are not regarded as the final basis of the actual object. DONJOY reserves the right to update the data without further notice.

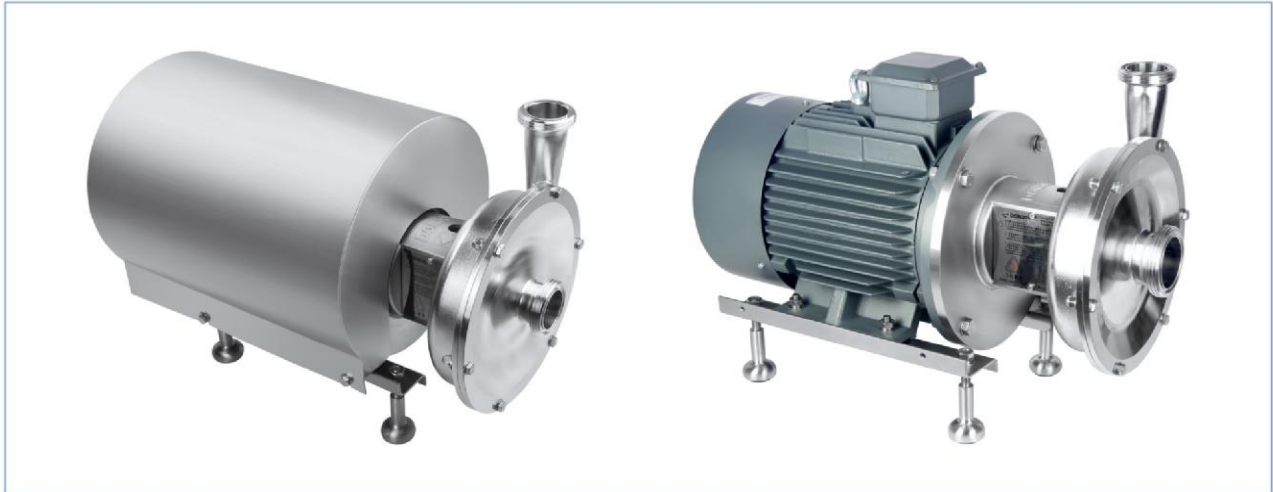

型号 Model	功率 Power	流量 Flow (m ³ /h)	扬程 Head (M)	进口/出口 Inlet/Outlet	理论重量 KG
DJ-LX-35-1	11KW	10	70	3"/1.5"	152
	11KW	15	65		152
	11KW	20	65		152
	11KW	25	60		152
	11KW	30	60		152
	11KW	35	55		152
	15KW	40	50		165
	15KW	45	50		165
	15KW	50	45		165
	DJ-LX-35-2	15KW	20		70
15KW		25	70	165	
15KW		30	70	165	
15KW		35	65	165	
15KW		40	65	165	
18.5KW		45	60	174	
18.5KW		50	55	174	

型号 Model	功率 Power	流量 Flow (m ³ /h)	扬程 Head (M)	进口/出口 Inlet/Outlet	理论重量 KG
DJ-LX40-1	11KW	45	42	3"/2.5"	148
	11KW	50	42		148
	15KW	60	40		162
	15KW	65	40		162
	15KW	70	38		162
	15KW	80	35		162
	15KW	90	33		162
	18.5KW	100	30		171
	18.5KW	110	28		171
	DJ-LX-40-2	15KW	50		50
15KW		60	48	162	
18.5KW		70	47	171	
18.5KW		80	46	171	
22KW		85	45	205	
22KW		90	44	205	
22KW		100	43	205	
22KW		110	40	205	
22KW		120	35	205	
30KW		130	30	263	
30KW	140	20	263		

注意：以上数据图相关尺寸不作为实物最终依据，东正保留对于数据更新权限不再另行通知。

Note: The relevant dimensions of the above data diagrams are not regarded as the final basis of the actual object. DONJOY reserves the right to update the data without further notice.

DJ-LX 系列离心泵数据图

DJ-LX Series centrifugal pump data chart

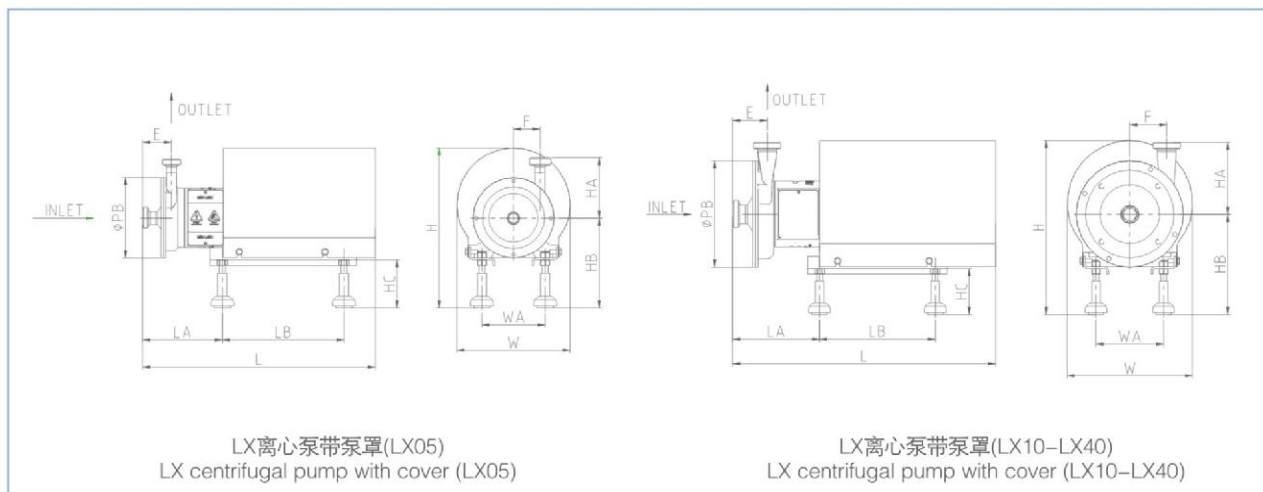

DJ-LX 系列 Series	泵头规格 Pump head dimension				外形安装尺寸 Assembly dimension							进/出口连接方式 Inlet / outlet connection											
	功率 Power (KW)	进口 Inlet	出口 Outlet	ΦPB	F	LB	H	HB	HC	W	WA	SMS 螺纹连接 (Thread)				INCH 卡箍连接 (Clamp)				DIN 螺纹连接 (Thread)			
												E	LA	HA	L	E	LA	HA	L	E	LA	HA	L
DJ-LX05	0.37-0.55KW	1"	0.75"	160	53	240	298	170	94.8	204	112	51	153	109	453	53	153	103	446	51	152	109	453
	0.75-1.1KW	1"	0.75"	160	53	240	317	178		224	125	51	153	109	453	53	153	103	446	51	152	109	453
DJ-LX10	1.1kw	1.5"	1.5"	222	77	240	317	199		250	125	66	173	150	514	57	165.7	143	506	66	173	150	514
	1.5-2.2KW	1.5"	1.5"	222	77	240	362	209		260	140	66	173	150	536	57	165.7	143	529	66	173	150	541
DJ-LX15	1.5-2.2KW	2"	1.5"	268	98	240	362	209		260	140	66	173	180	536	57	165.7	173	529	67	174	180	537
	3KW	2"	1.5"	268	98	300	413	218		320	160	66	153	180	578	57	145.7	173	571	67	154	180	579
DJ-LX20-1	3KW	2"	2"	282	101	300	416	218		320	160	74.5	166	200	584	67	158.2	193	577	75.5	166.5	201	585
	4KW	2"	2"	282	101	300	421	210		340	190	74.5	173	200	591	67	165.2	193	584	75.5	173.5	201	592
DJ-LX20-2	5.5-7.5KW	2"	2"	282	101	330	466	231		380	216	74.5	206	200	675	67	198.7	193	668	75.5	207	201	676
	5.5-7.5KW	2.5"	2"	282	101	330	466	231		380	216	78.5	210	200	679	67	199	193	668	77.5	209	201	678
DJ-LX25	4KW	2.5"	1.5"	328	128	300	421	211		340	190	72	172	210	591	61	160.2	203	580	71	170.5	210	590
	5.5-7.5KW	2.5"	1.5"	328	128	330	466	231		380	216	72	206	210	685	61	194.2	203	674	71	204.5	210	684
DJ-LX30	5.5-7.5KW	2.5"	1.5"	328	128	330	466	231		380	216	72	206	210	685	61	194.2	203	674	71	204.5	210	684
DJ-LX35-1	11-15KW	3"	1.5"	363	141	450	551	260		470	254	78.5	234	235	809	67	222.2	228	797	79.5	233.5	235	809
	15KW	3"	1.5"	363	141	450	551	260		470	254	78.5	234	235	809	67	222.2	228	797	79.5	233.5	235	809
DJ-LX35-2	15.5KW	3"	1.5"	363	141	450	551	260		470	254	78.5	234	235	809	67	222.2	228	797	79.5	233.5	235	809
	15KW	3"	2.5"	335	120	450	551	260		470	254	89.5	246	239	820	78	234.2	228	809	88.5	244.5	238	819
DJ-LX40-1	18.5KW	3"	2.5"	335	120	450	551	261		470	254	89.5	246	239	820	78	234.2	228	809	88.5	244.5	238	819
	22KW	3"	2.5"	335	120	515	583	281		510	279	89.5	241	239	916	78	229.2	228	904	88.5	239.5	238	915
DJ-LX40-2	30KW	3"	2.5"	335	120	580	655	301		580	318	89.5	252	239	962	78	240.2	228	950	88.5	250.5	238	961

注意：以上数据图相关尺寸不作为实物最终依据，东正保留对于数据更新权限不再另行通知。
 Note: The relevant dimensions of the above data diagrams are not regarded as the final basis of the actual object. DNJOY reserves the right to update the data without further notice.

DJ-LX 系列离心泵数据图(不带外罩)

DJ-LX Series centrifugal pump data chart without cover

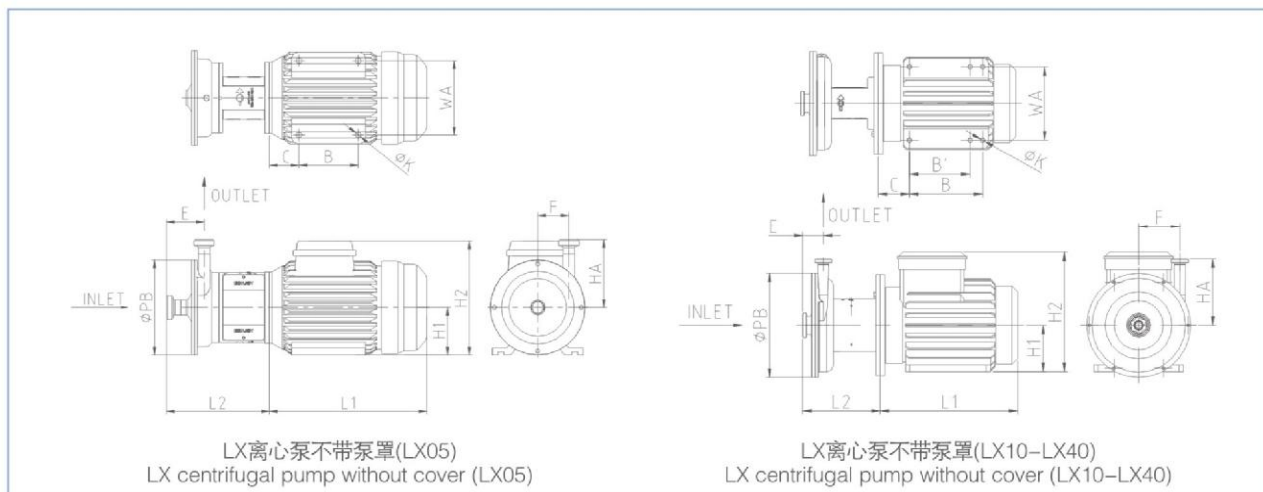

DJ-LX系列 DJ-LX Series	泵头规格 Pump head dimension				外形安装尺寸 Assembly dimension									进/出口连接方式 Inlet / outlet connection								
	功率 Power(KW)	进口 Inlet	出口 Outlet	ØPB	F	L1	WA	B	B'	C	K	H1	H2	SMS 螺纹连接 (Thread)			INCH 卡箍连接 (Clamp)			DIN 螺纹连接 (Thread)		
														E	L2	HA	E	L2	HA	E	L2	HA
DJ-LX05	0.37-0.55KW	1"	0.75"	160	53	227	125	100	\	50	7	71	175	51	161	109	53	163	93	51	162	109
	0.75-1.1KW	1"	0.75"	160	53	269	125	100	\	50	10	80	192	51	161	109	53	163	93	51	162	109
DJ-LX10	1.1KW	1.5"	1.5"	222	77	269	125	100	\	50	10	80	192	66	198	150	58	191	143	66	198	150
	1.5KW	1.5"	1.5"	220	77	285	140	100	\	56	10	90	217	66	198	150	58	191	143	66	198	150
DJ-LX15	2.2KW	1.5"	1.5"	220	77	301	140	125	\	56	10	90	217	66	198	150	58	191	143	66	198	150
	1.5KW	2"	1.5"	266	100	285	140	100	\	56	10	90	217	66	195	180	59	188	173	67	195	180
DJ-LX15	2.2KW	2"	1.5"	266	100	301	140	125	\	56	10	90	217	66	195	180	59	188	173	67	195	180
	3KW	2"	1.5"	266	100	346	160	140	\	63	12	100	240	66	195	180	57	188	173	66	195	180
DJ-LX20-1 DJ-LX20-2	3KW	2"	2"	280	101	346	160	140	\	63	12	100	240	75	207	200	67	200	193	76	208	201
	4KW	2"	2"	280	101	351	190	140	\	70	12	112	252	75	207	200	67	200	193	76	208	201
DJ-LX25	5.5-7.5KW	2"	2"	280	101	399	216	140	\	89	12	132	301	75	207	200	67	200	193	76	208	201
	5.5-7.5KW	2.5"	2"	282	101	399	216	140	\	89	12	132	301	79	211	204	67	200	193	78	210	201
DJ-LX25	4KW	2.5"	1.5"	328	128	351	190	140	\	70	12	112	252	72	207	210	61	196	203	71	206	210
	5.5-7.5KW	2.5"	1.5"	328	128	399	216	140	\	89	12	132	301	72	207	210	61	195	203	71	206	210
DJ-LX30	5.5-7.5KW	2.5"	1.5"	328	128	399	216	140	\	89	12	132	301	72	207	210	61	195	203	71	206	210
DJ-LX35-1	11-15KW	3"	1.5"	360	143	477	254	254	210	108	15	160	413	79.5	276	235	67	265	228	79.5	275	235
DJ-LX35-2	15KW	3"	1.5"	360	143	477	254	254	210	108	15	160	413	79.5	276	235	67	265	228	79.5	275	235
	18.5KW	3"	1.5"	360	143	477	254	254	210	108	15	160	413	79.5	276	235	67	265	228	79.5	275	235
DJ-LX40-1 DJ-LX40-2	15KW	3"	2.5"	332	122	477	254	254	210	108	15	160	413	90	289	239	78	278	228	90	289	239
	18.5KW	3"	2.5"	332	122	477	254	254	210	108	15	160	413	90	289	239	78	278	228	90	289	239
DJ-LX40-1 DJ-LX40-2	22KW	3"	2.5"	332	122	573	279	279	241	120	15	180	434	90	289	239	78	278	228	90	289	239
	30KW	3"	2.5"	332	122	618	318	305	267	133	19	200	473	90	289	239	78	278	228	90	289	239

注意：以上数据图相关尺寸不作为实物最终依据，东正保留对于数据更新权限不再另行通知。

Note: The relevant dimensions of the above data diagrams are not regarded as the final basis of the actual object. DNJOY reserves the right to update the data without further notice.

DJ-LX 系列离心泵曲线图

DJ-LX series centrifugal pump graph

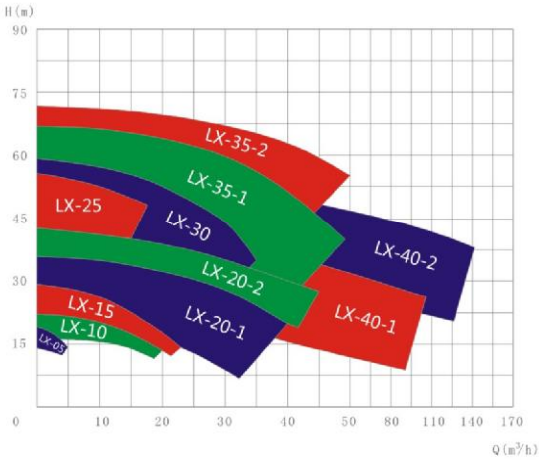

LX-05(Q-H曲线图/Graph)

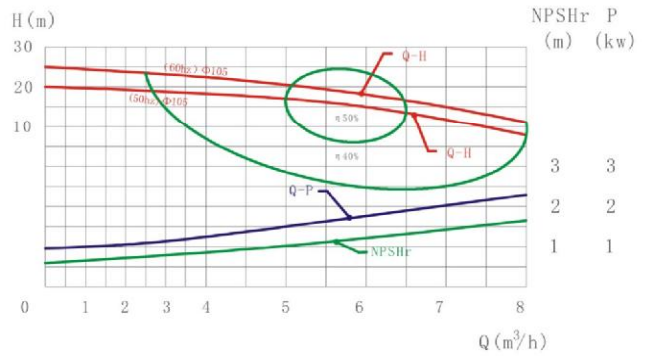

LX-10(Q-H曲线图/Graph)

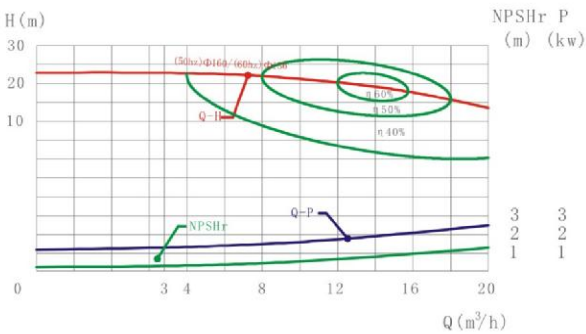

LX-15(Q-H曲线图/Graph)

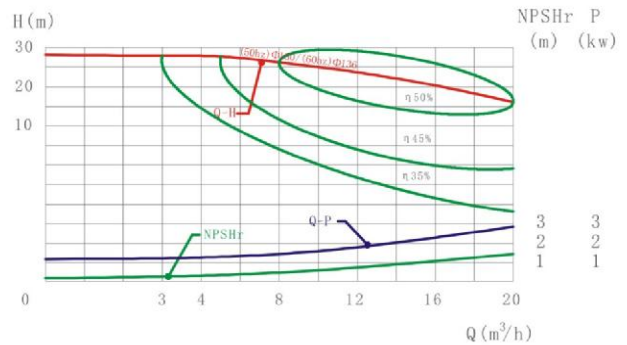

LX-20-1(Q-H曲线图/Graph)

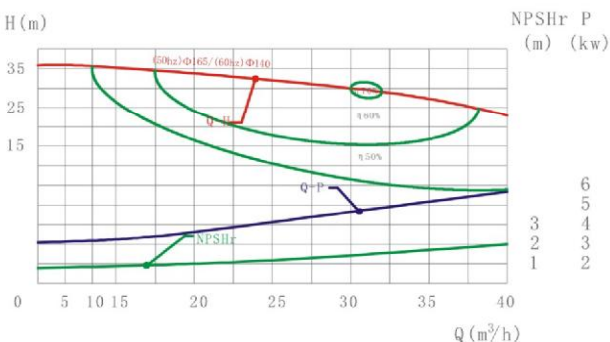

LX-20-2(Q-H曲线图/Graph)

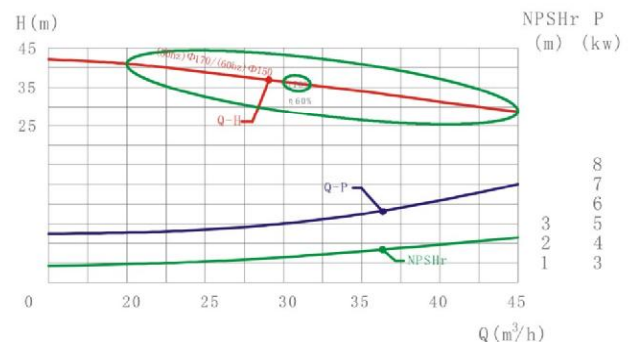

测试条件: 介质清水, 温度20°C, 叶轮转速2900 R.P.M

(此曲线图亦适用电机60Hz, 叶轮转速3600R.P.M) Q-流量(m³/H), H-扬程(M), P-功率(KW), η%-泵效率。

Testing condition: medium water, temperature 20 °C, impeller speed 2900 RPM (This graph also applies to motor 60HZ, impeller speed 3600RPM) Q-Flow rate (m³/H), H-head (meter), P-power (KW), η % pump efficiency

LX-25(Q-H曲线图/Graph)

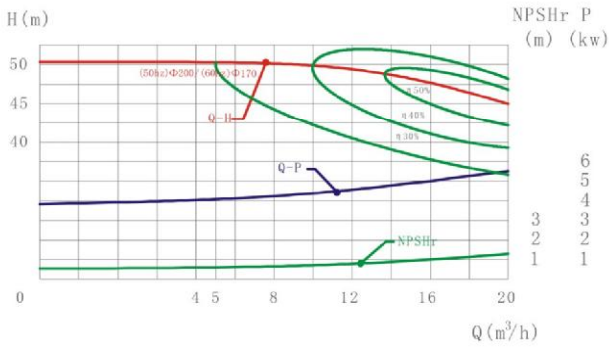

LX-30(Q-H曲线图/Graph)

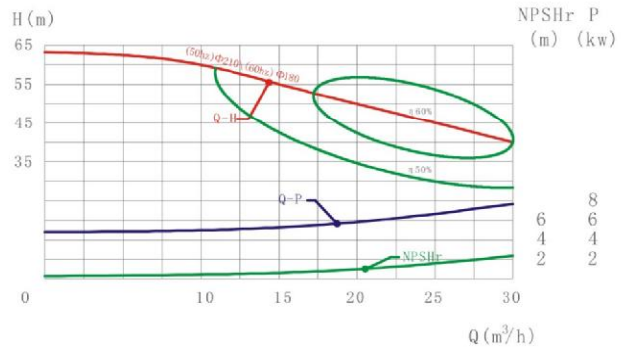

LX-35-1(Q-H曲线图/Graph)

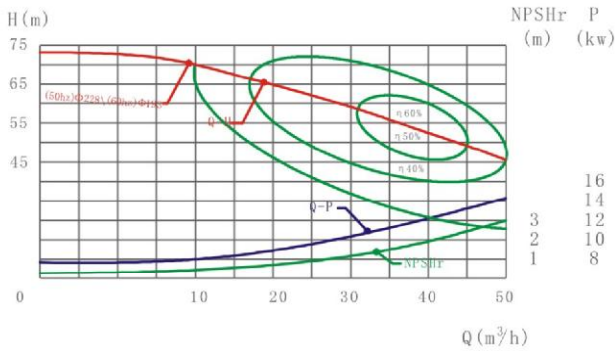

LX-35-2(Q-H曲线图/Graph)

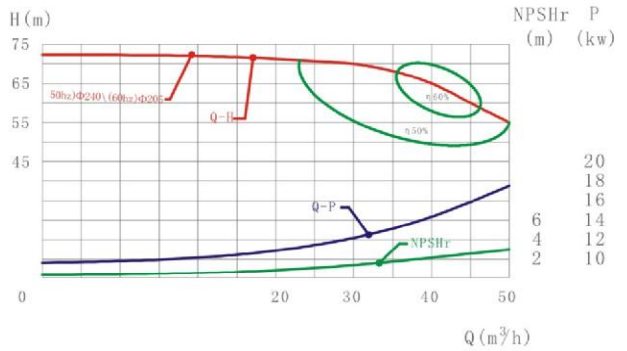

LX-40-1(Q-H曲线图/Graph)

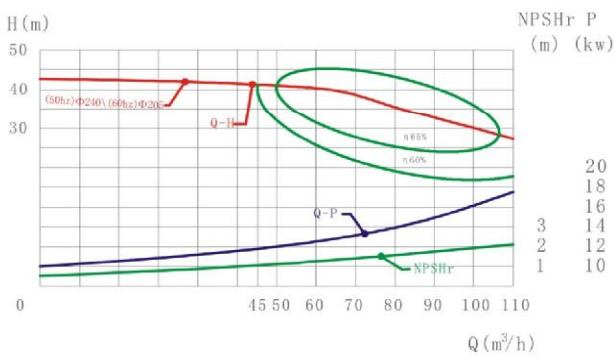

LX-40-2(Q-H曲线图/Graph)

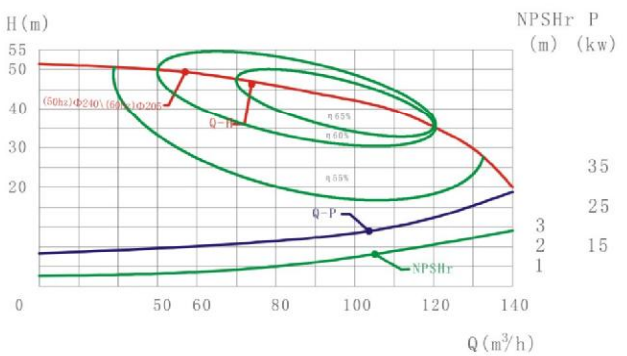

测试条件: 介质清水, 温度20°C, 叶轮转速2900 R.P.M

(此曲线图亦适用电机60Hz, 叶轮转速3600R.P.M) Q-流量(m³/H), H-扬程(M), P-功率(KW), η%-泵效率。

Testing condition: medium water, temperature 20 °C, impeller speed 2900 RPM (This graph also applies to motor 60HZ, impeller speed 3600RPM) Q-Flow rate (m³/H), H-head (meter), P-power (KW), η % pump efficiency